



AMR (Inc. TLG) MANUFACTURING PTY LTD

LPG and CNG Gas Conversion Equipment

33 Downing Street, Oakleigh VIC 3166 Australia
 Tel: +61 3 9563 1508 Fax: +61 3 9564 7232
 Email: sales@amrgas.com www.amrgas.com

VAPOUR SEQUENTIAL INJECTION LPG CONVERTER EXCHANGEABLE FOR A COMPREHENSIVE RANGE OF VSI VEHICLES

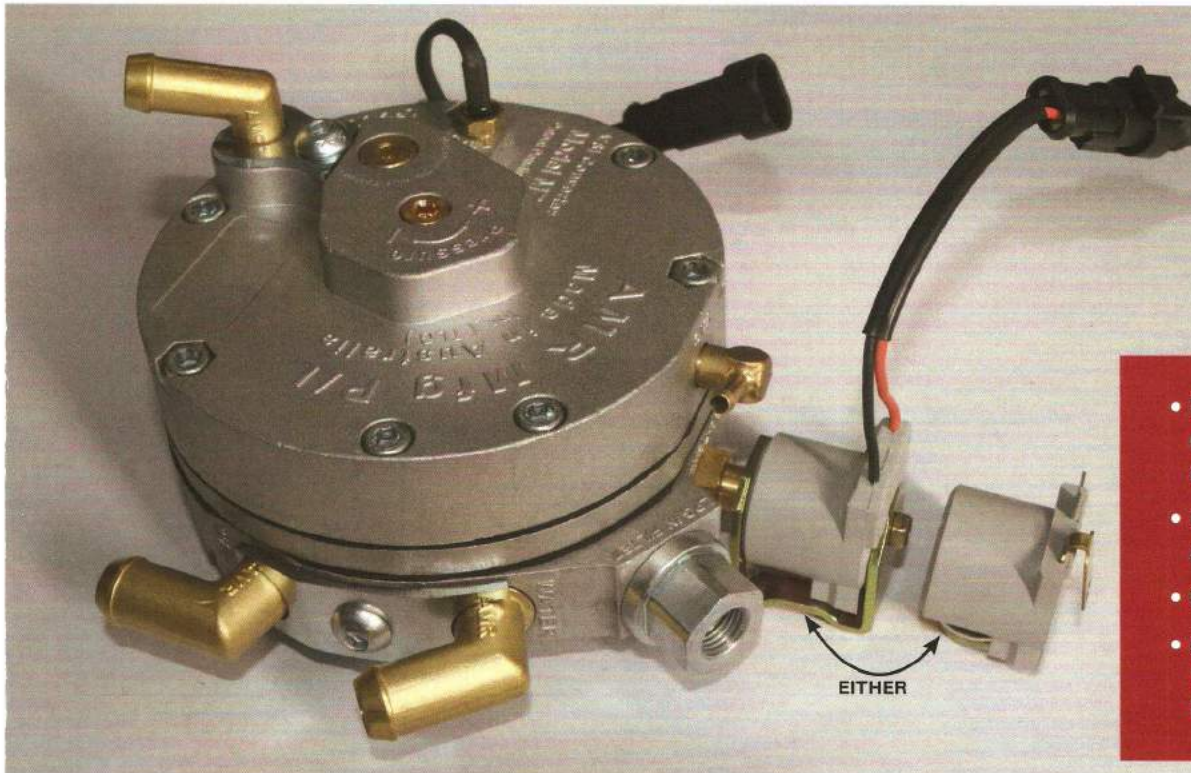

- Engineering designed high quality components for reliability and endurance.
- Extremely compact and powerful.
- Competitively Priced.
- Complies with AS/NZS 1425:2013 and European ECE R67 Standards.

INCORPORATES GAS LOCK OFF AND FILTER (FOR EASY REPLACEMENT)

FEATURES — MODEL M7

- LOCK OFF SOLENOIDS 12V D.C. & 24V D.C. ARE AVAILABLE WITH MALE TERMINAL OR FEMALE PLUG/LOOM (FOR EASY REPLACEMENT)
- HAS SIDE AND BACK MOUNT HOLES M8 THREAD
- COMES WITH MOUNT BRACKET, STUD, WASHHER & NUT
- HEAT SHIELD KIT AVAILABLE
- INCORPORATES TEMPERATURE SENSOR WITH PLUG LOOM VARIOUS PLUGS AND OHMS ALSO AVAILABLE
- ADJUSTABLE WORKING PRESSURE RANGE 1 — 2.7 BAR. COMES SET TO 1.5 BAR
- MAX INLET PRESSURE 2.55MPA
- ENGINE POWER FROM 50KW TO 430KW/575HP
- OPERATING TEMPERATURE RANGE - 40°C TO +120°C
- GAS INLET THREAD 1/4 NPT
- BRASS WATER ELBOWS TO SUIT 5/8 16MM I.D HOSE 360° ROTATION + 10MM STRAIGHT
- BRASS ELBOW GAS OUTLET VAPOUR TO SUIT 12MM I.D & 16MM I.D HOSE 360° ROTATION + 11MM, 12MM & 14MM IN STRAIGHT
- BRASS BRASS STRAIGHT VACUUM FITTING TO SUIT 6MM I.D HOSE
- ASSEMBLED WEIGHT 2.3KG
- CONVERTER SIZE : 135MM DIAMETER AND 74MM THICK

AUSTRALIAN MADE - THE STRENGTH OF QUALITY

VAPOUR SEQUENTIAL INJECTION LPG CONVERTER

INCORPORATES GAS LOCK OFF AND FILTER DISPLAY

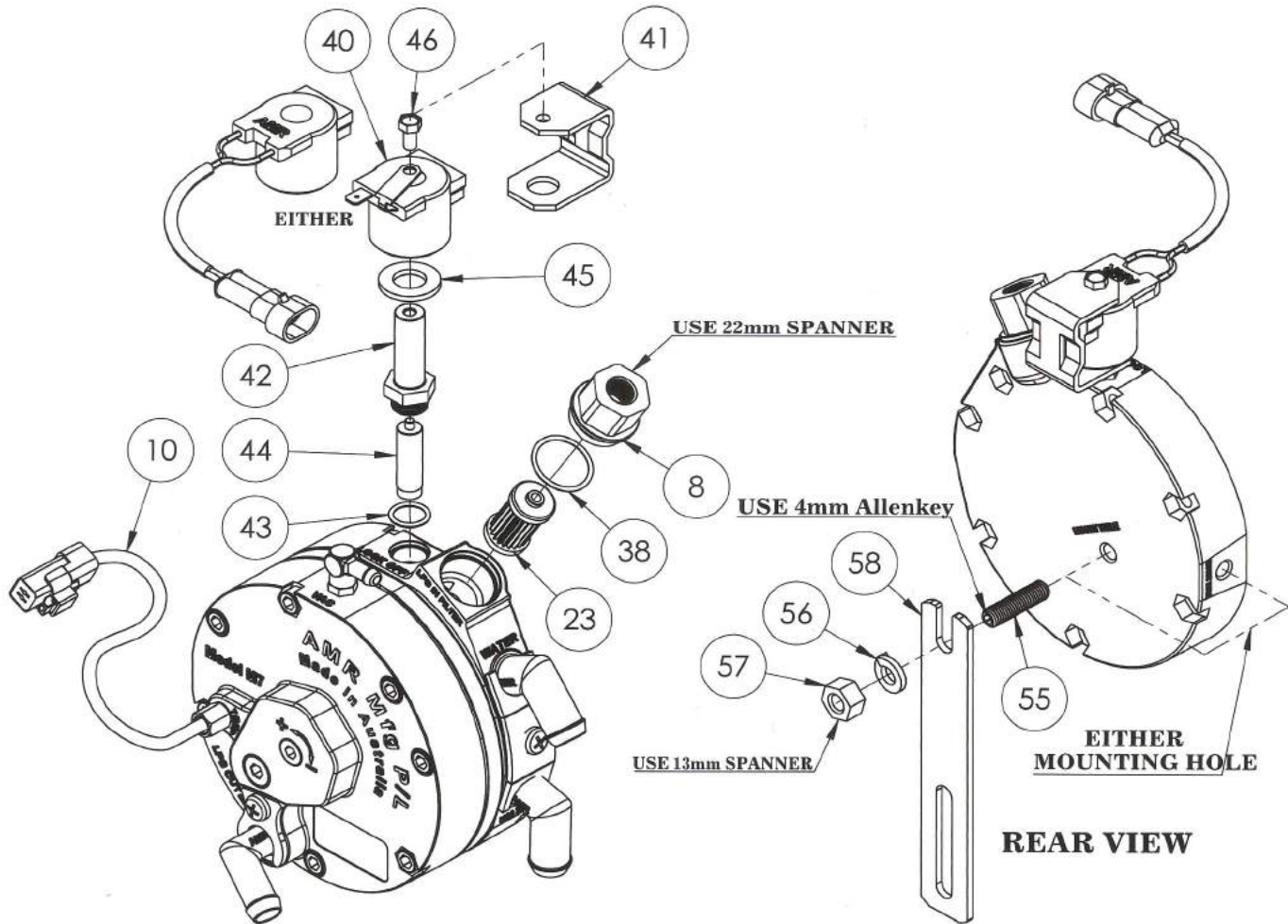

INDEX No.	DESCRIPTION	PART No.
10	TEMP SENSOR	VICTS 5177
23	FILTER	L-CL20RK
38	FILTER CAP O RING	BS 019 VITON
8	INLET FITTING TIGHTEN TO 10NM	VIII 5D3
43	O RING - NITRILE	BS 014 VITON
44	PLUNGER	GL300500
42	VALVE STEM TIGHTEN TO 10NM	GL300300
45	COIL WASHER	GHL20CW
40	SOLENOID ASSEMBLY	L-GL300100
40A	SOLENOID WITH LOOM	LP-GLV3453
46	M5 x 10 SET SCREW	M5105
41	SOLENOID BRACKET	GL30LPUB
57	M8 NUT	
56	M8 SPRING WASHER	
58	CONVERTER BRACKET	VCB5337
55	M8 x 30 STUD	

WHEN CONNECTING BARE WIRES, WE RECOMMEND THE PRACTICE OF SOLDERING AND THE USE OF INSULATION.

WE RECOMMEND NON-ADDITIVE MINERAL OIL TO BE APPLIED TO O-RINGS ON RE-ASSEMBLY.

WARNING:

Improper installation or use of this LPG product may cause serious injury and/or property damage.

INSTALLERS:

The installation of this product should be carried out by an Accredited Installer of your state within Australia; in accordance with AS/NZS 1425:2013 or to the regulations and bodies of other countries.

DISTRIBUTED BY:

In the interest of continuous improvement, AMR Manufacturing PTY. LTD. reserves the right to change the specifications or design of any of its products without prior notice.



ACN 060 595 413

AMR (Inc. TLG) MANUFACTURING PTY LTD
LPG and CNG Gas Conversion Equipment

33 Downings Street, Oakleigh VIC 3166 Australia
Tel: +61 3 9563 1508 Fax: +61 3 9564 7232
Email: sales@amrgas.com www.amrgas.com